

**SS**

Precision High Speed  
Automatic Press Series

33-140 US Tons Capacity

*SS-3*  
*SS-6*  
*SS-8*  
*SS-12*



## Product Overview

The SS press series is a straightside precision mechanical press with excellent value. It features models ranging from 300-1250kN or 33-140 US tons capacity

- High rigidity frame with tie-rod construction
- Eccentric load support through precise eight point slide guiding system (SS-3 uses four point guiding system)
- Wide bolster to accommodate multi-step progressive dies
- Dynamic accuracy with specific measurement of thermal displacement and bottom-dead-center repeatability



Model		SS-3			SS-6			
Tons Capacity	kN	300			600			
Stroke Length	mm	20	25	30	25	40	60	80
Maximum SPM	spm	900		800	750	550	400	350
Minimum SPM	spm	200			150		80	
Force Point	mm	2.0			2.0			
Die Height	mm	240	235		345	340	330	320
Die Height Adjustment	mm	30			50			
Slide Area	mm	500 x 340			950 x 480			
Bolster Area	mm	550 x 340			950 x 600			
Bolster Thickness	mm	90			140			
Bed Opening	mm	400 x 120			800 x 200			
Bolster Opening	mm	320 x 80			700 x 140			
Main Motor	kWt	5.5			15			
JIS Accuracy		Special Grade			Special Grade			
Max Upper Die Weight	kg	Max. 60			Max. 200			
Gross Weight	kg	4100			11000			

## Specifications and Dimensions

The SS press series is a complete straightside press with tie rod construction. From precision stamping of connectors, general parts and motor cores, increased frame rigidity makes this series a highly versatile solution.



SS-3



SS-6



SS-8



SS-12

Model		SS-8							SS-12				
Tons Capacity	kN	800							1250				
Stroke Length	mm	20	30	50	60	80	100	150	30	40	50	60	70
Maximum SPM	spm	700	600	350	300	230	180	120	600	500	350	300	260
Minimum SPM	spm	180			80				150				
Force Point	mm	3.2			2.0				2.0				
Die Height	mm	370	365	355	350	340	330	305	380	375	370	365	360
Die Height Adjustment	mm	50							50				
Slide Area	mm	1200 × 600							1500 × 700				
Bolster Area	mm	1200 × 800							1500 × 800				
Bolster Thickness	mm	160							180				
Bed Opening	mm	900 × 200							1200 × 160				
Bolster Opening	mm	860 × 140							1160 × 120				
Main Motor	kW	22							37				
JIS Accuracy		Special Grade							Special Grade				
Max Upper Die Weight	kg	Max. 350 (300~500 special)							Max. 600				
Gross Weight	kg	16000							30000				

# Dimensions (mm)

## SS-3

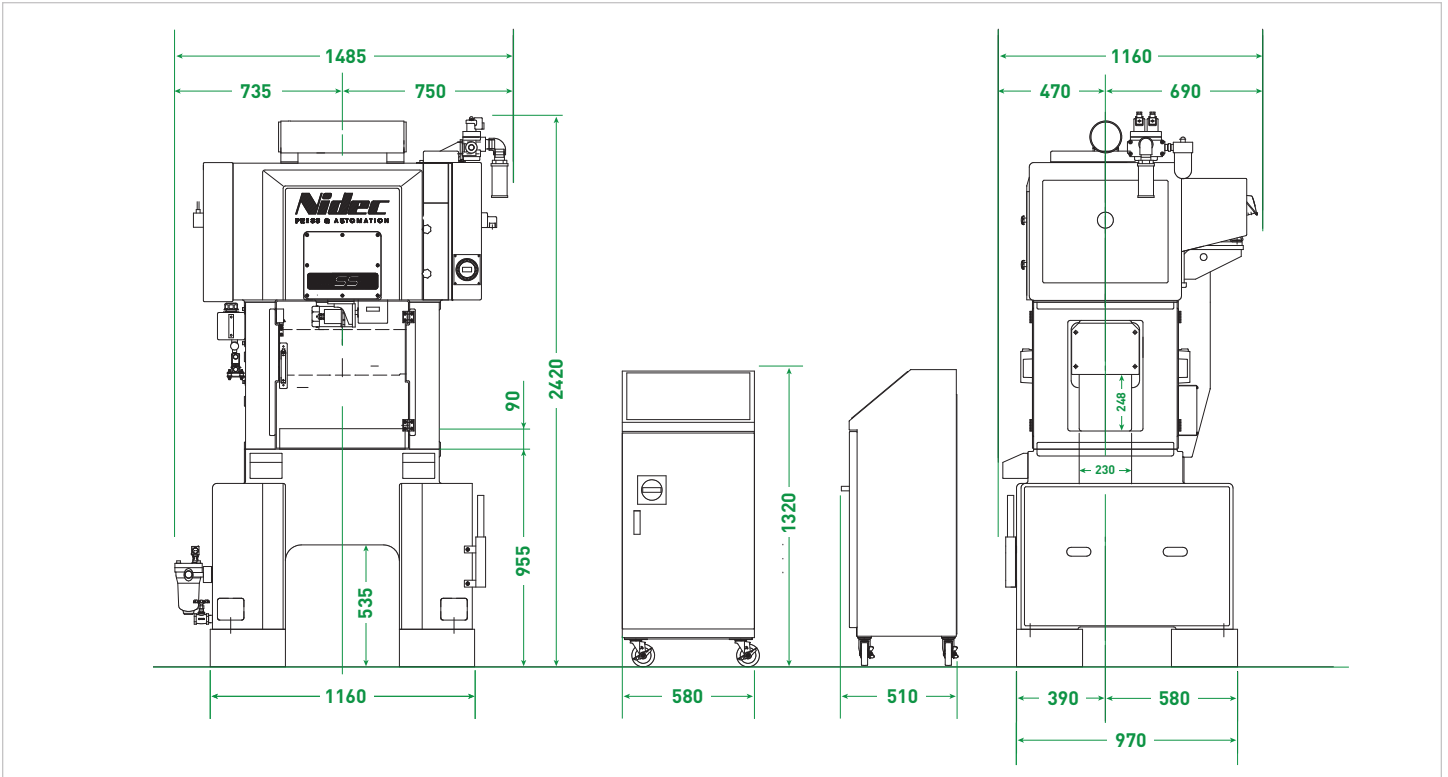

## SS-6

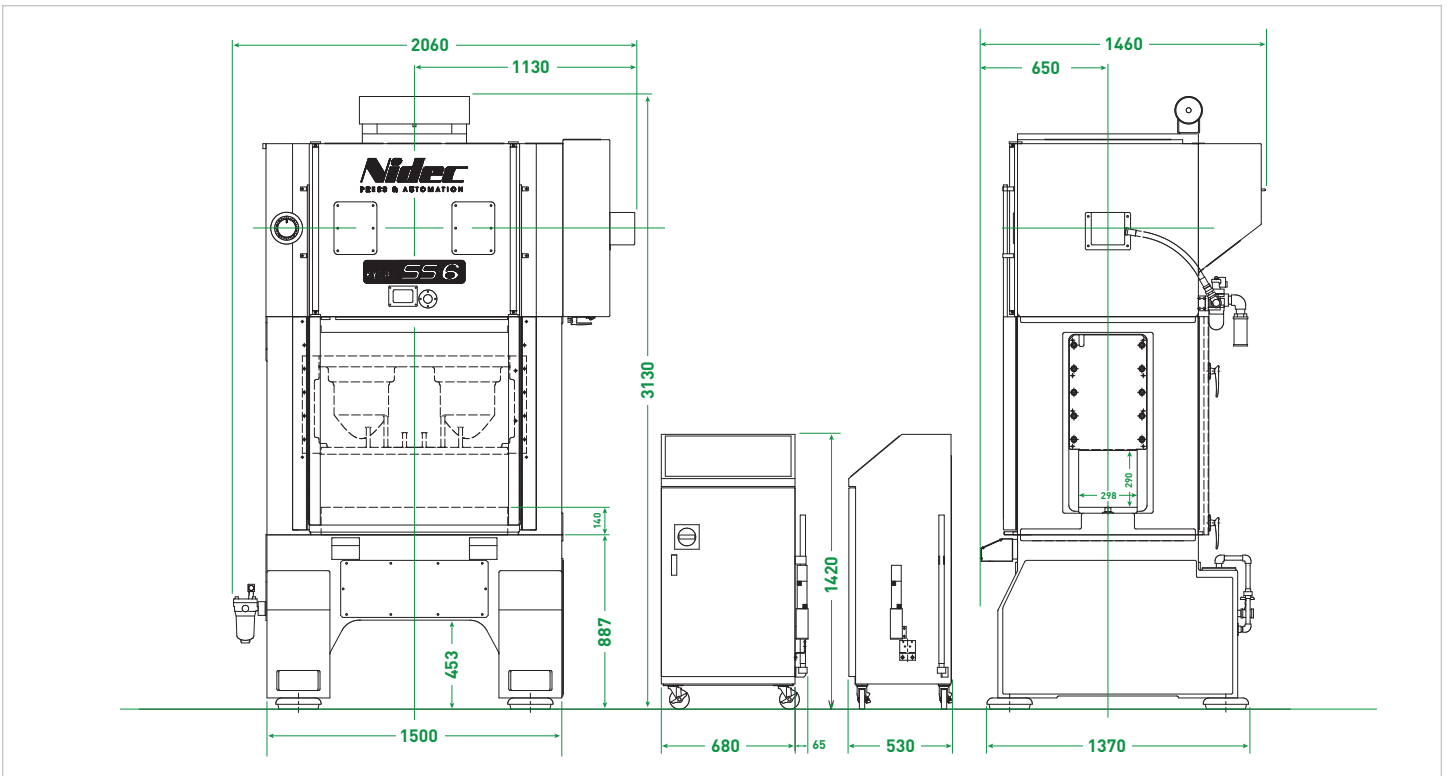

# SS-8

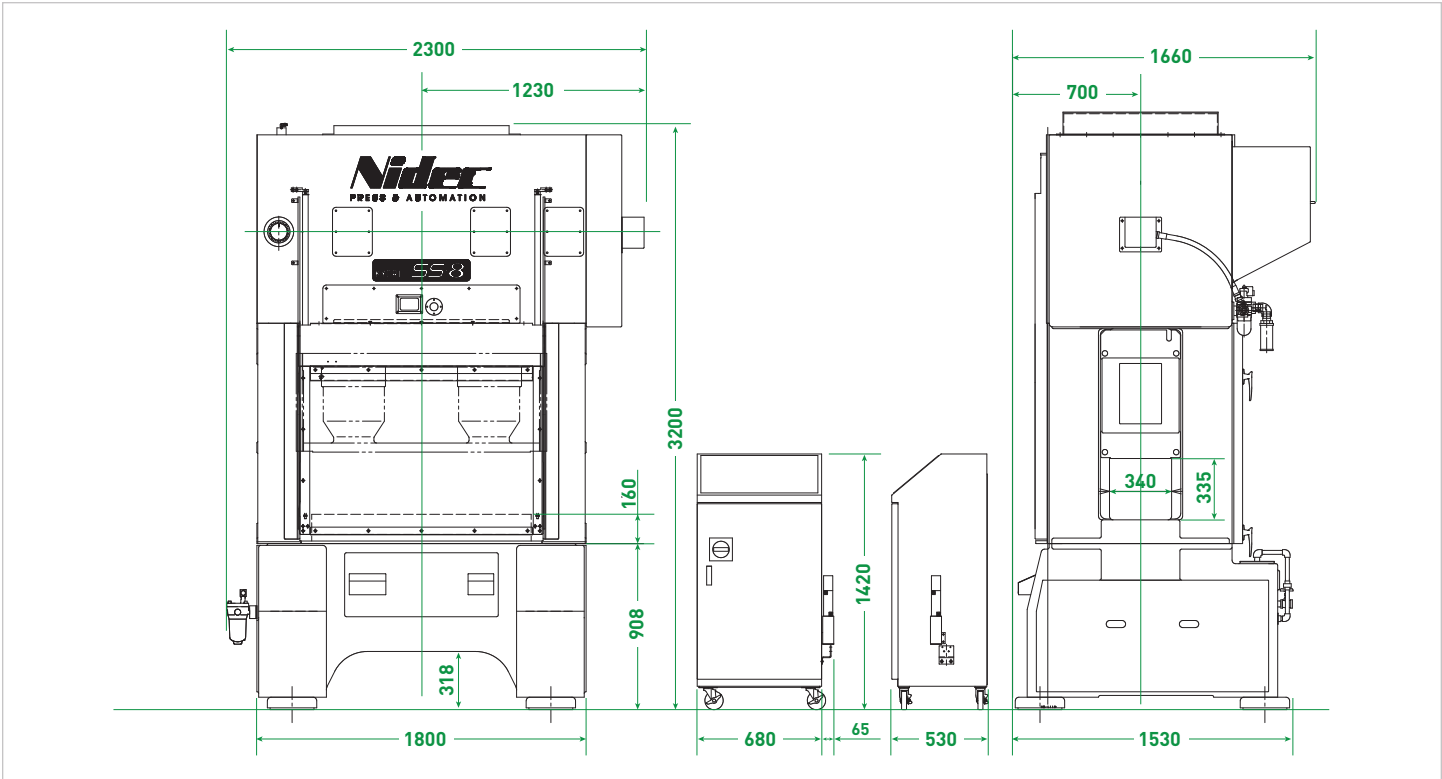

# SS-12

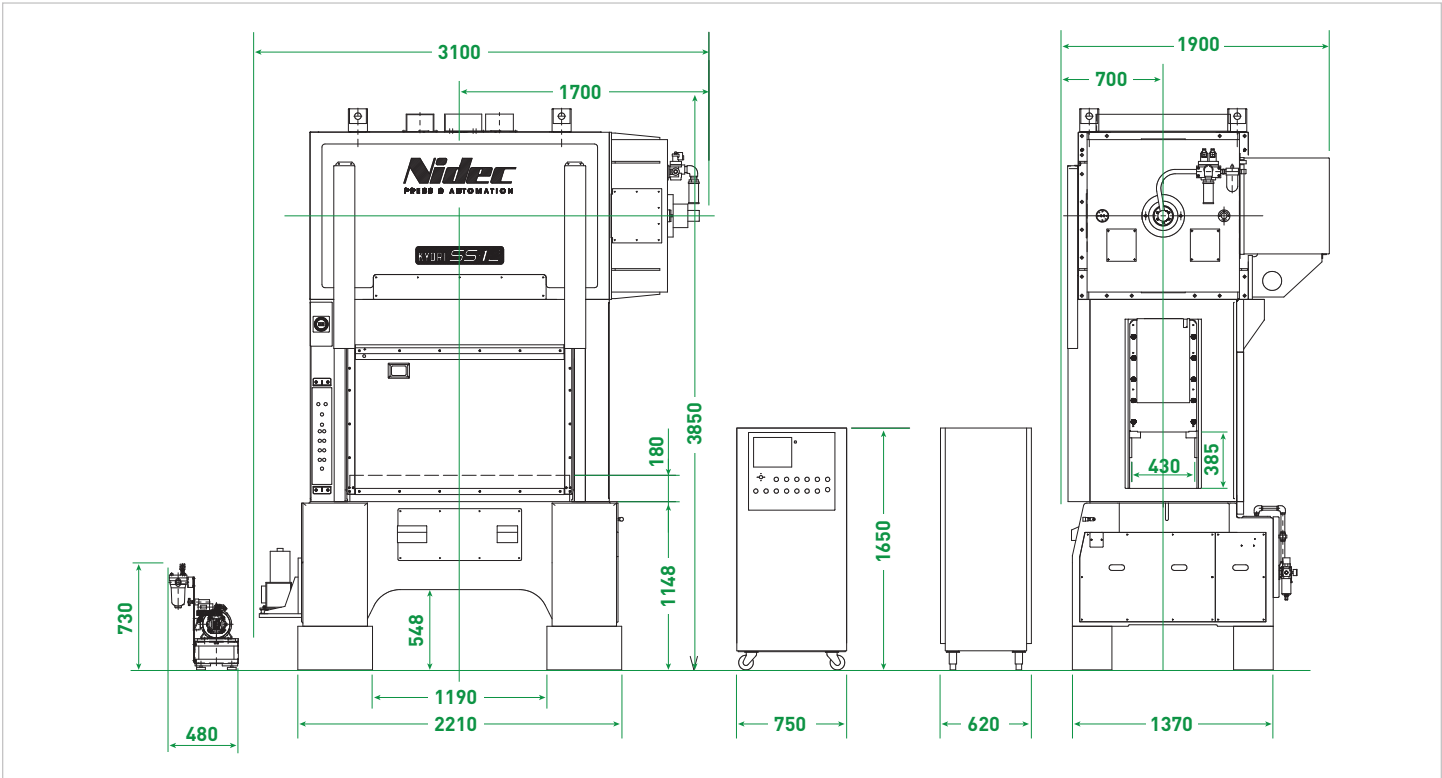

# Dimensions (mm)

SS-3

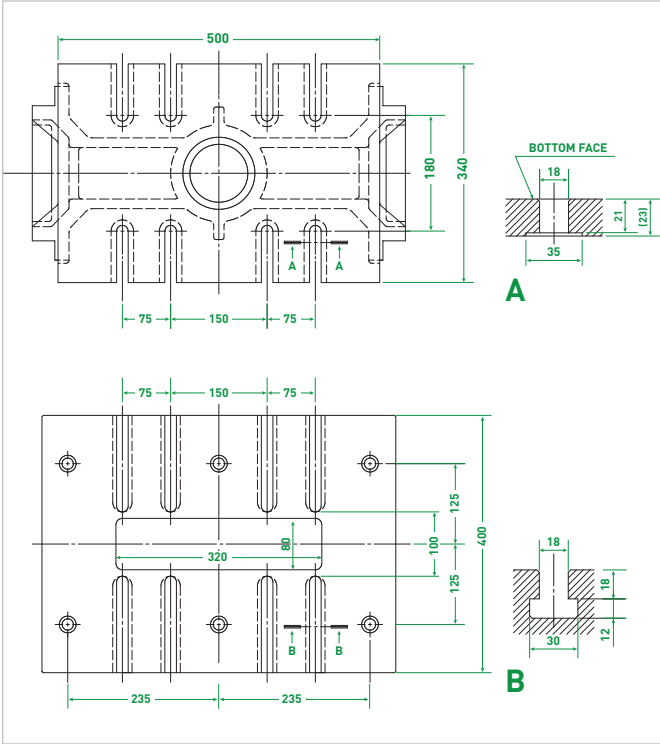

SS-6

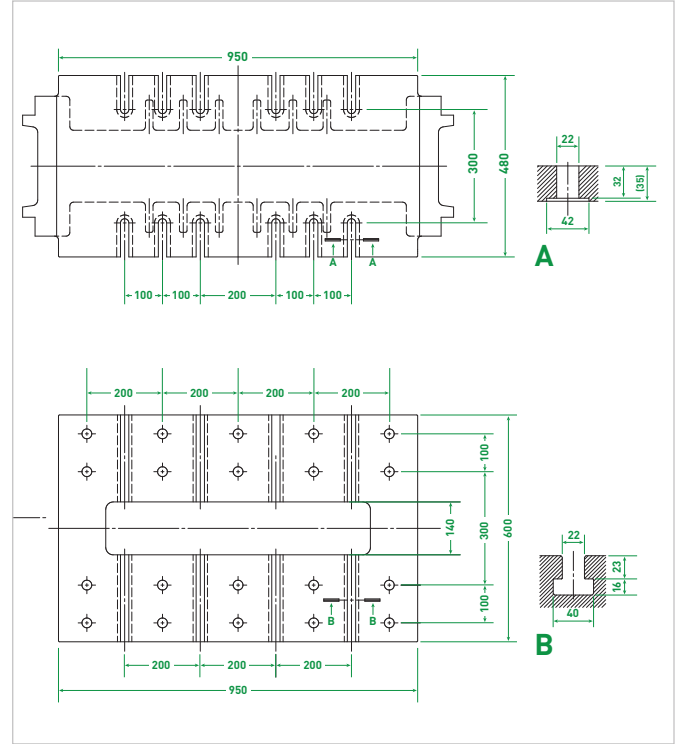

SS-8

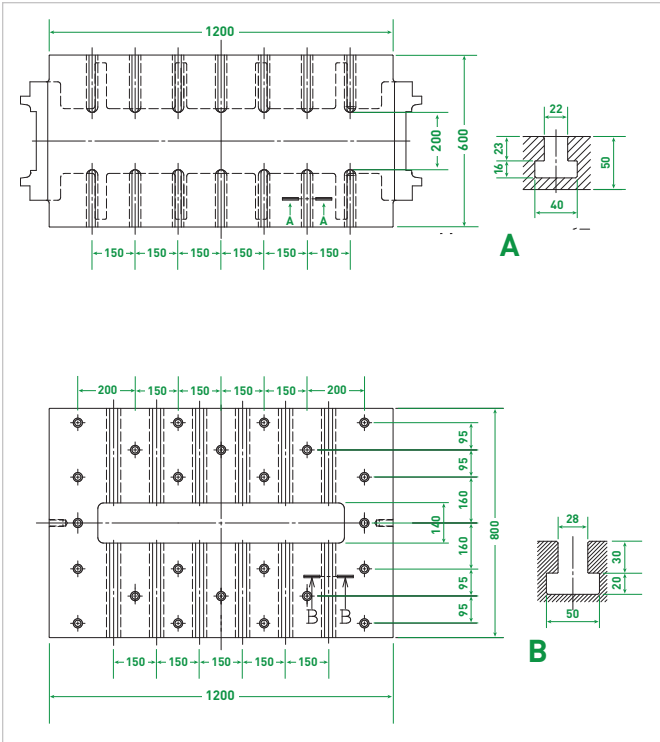

SS-12

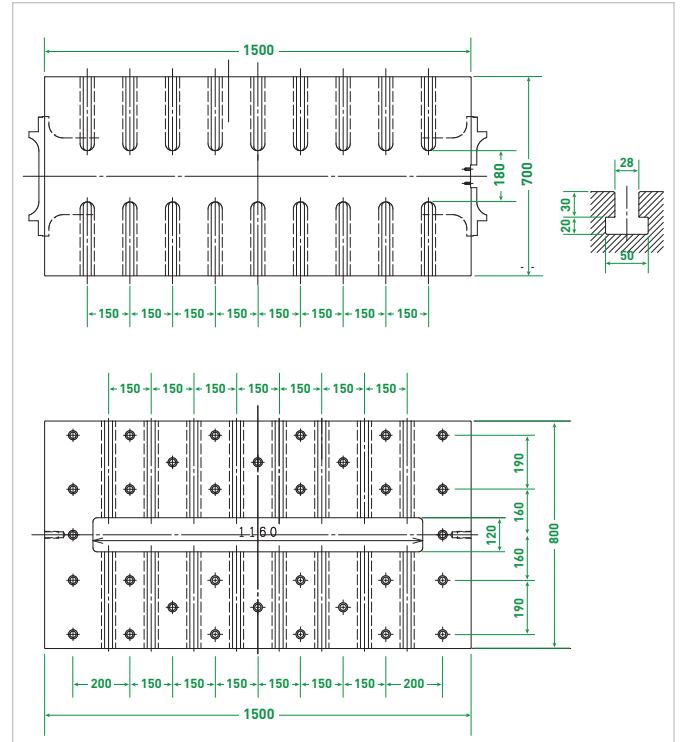

# Features

## Standard Features

- Inverter variable speed main motor
- Combination air friction clutch & brake
- Electronic rotary cam switch
- Automatic stop angle correction function
- Crank angle indicator
- HMI touchscreen
- Total counter (8 digits)
- Preset counter (8 digits)
- Hour meter (7 digits)
- Electronic slide adjustment
- Safety door
- Separate operation panel
- Micro-inching (reverse available)
- Motor reversing device
- Both hands push button
- Circulation type lubrication unit
- Pneumatic control unit
- Stock end stop switch (proximity type)
- Air outlet (1/4B)
- Two outlets for top-dead-center stop
- Two 380v outlets
- Safety block

## Optional Features

- Mechanical gripper feeder
- Shock absorbers
- Oil heater/cooler
- Stock oil tank(solenoid valve)
- Air ejector (solenoid valve)
- Die height detector
- Die area light
- Sound enclosure
- Index drive shaft
- Servo index unit
- Oiler
- Vamco scrap cutter
- Scrap conveyor
- Uncoiler/leveler

## Application Examples

The SS series offers a wide range of capabilities for precise applications.

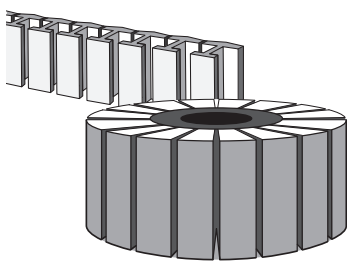

**SMALL MOTOR CORES**

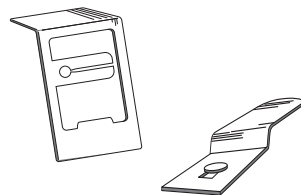

**SMALL ELECTRONIC COMPONENTS**

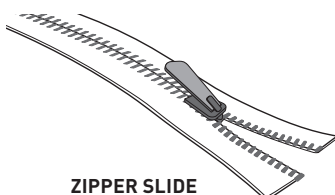

**ZIPPER SLIDE**

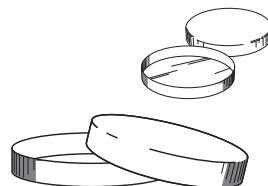

**COIN BATTERY CASES**



# 61 Senthil Kumar Rd, Shasta layout, Rayasandra,  
Bengaluru, Karnataka 560100  
Ph : 9446643615, 9740984615

[www.nemoinpresses.com](http://www.nemoinpresses.com) - [info@nemoinpresses.com](mailto:info@nemoinpresses.com)

## One Brand: A World of Resources

---

A single source solution that will help you find the efficiencies you want — all from the products, services and technology of Nidec Press & Automation.

[nidecpa.com](http://nidecpa.com)